

UC4i+

Universal Converter + IoT card (v3.x differential measuring range)

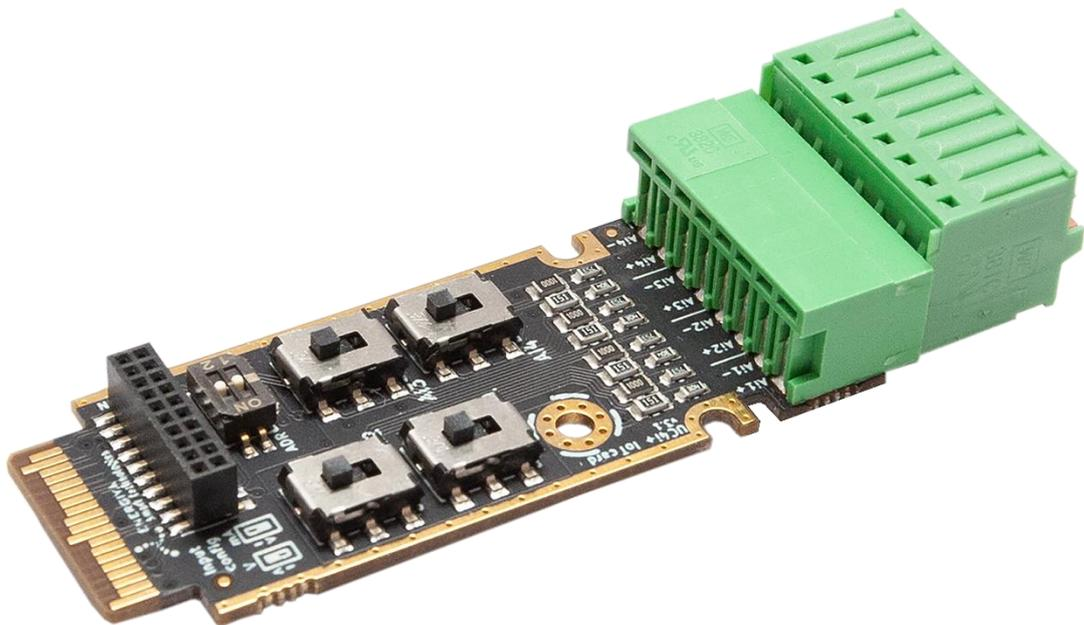

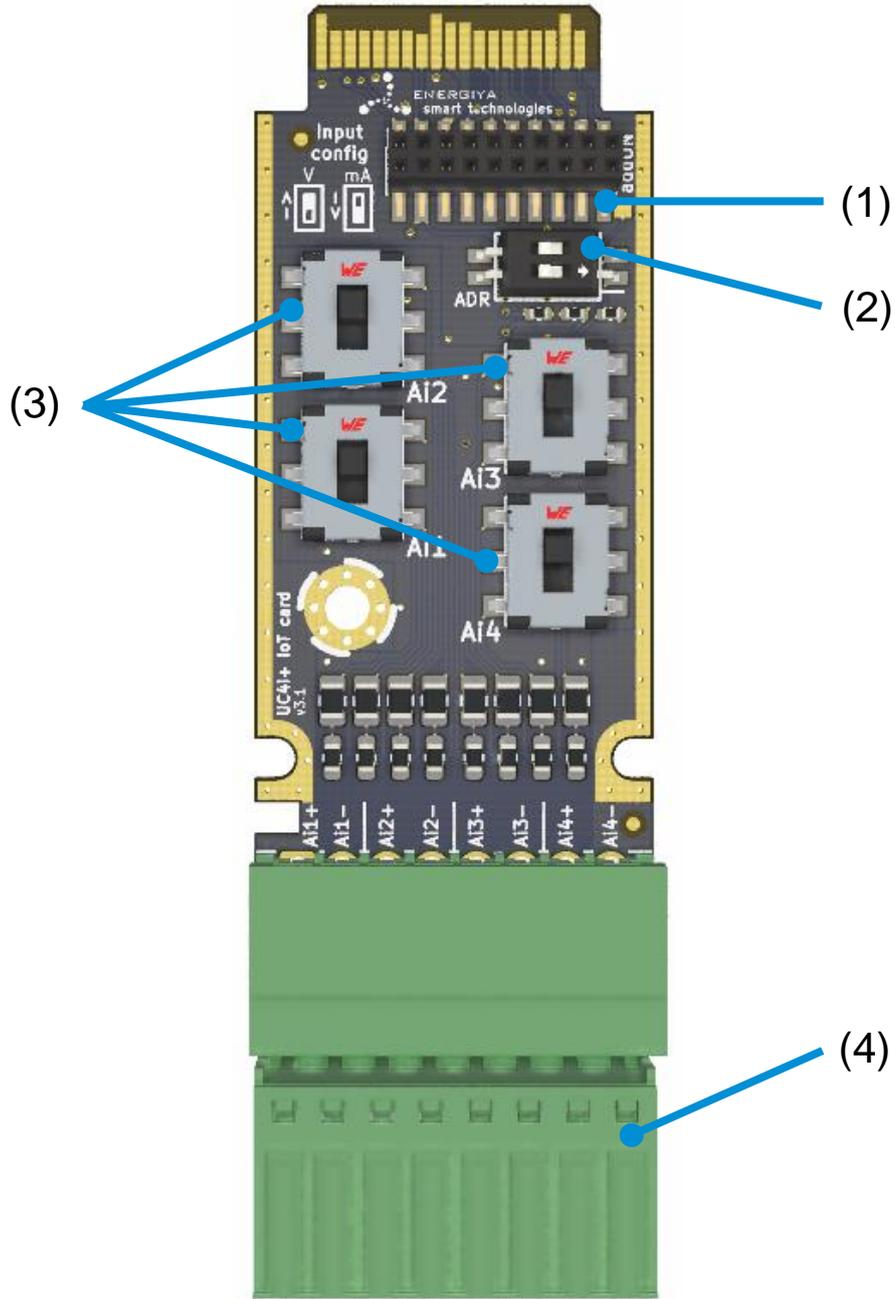

fig. 1

-
- (1) addON socket

 - (2) I2C address switch

 - (3) inputs configuration switches

 - (4) analog inputs connector

Description

Universal Converter is 4 configurable analog inputs card. The IoT card allows for current (-20 to +20 mA) and voltage (-10 to +10 V) measurement.

Thanks to a special connector, the device has the possibility to extend its functionality with addON expansion cards.

The IoT card is compatible with mangOH Green, Red, Yellow and FX30 / FX30S.

Mounting the card in the host

It is recommended to install the IoT card when the power is off to avoid accidental short circuits. If the card is installed with the power on, it is necessary to reboot the program.

Depending on the device used, the card is mounted using standoffs/spacers (mangOH) or rails (FX30). The IoT card also have dedicated cover for locking inside FX30.



Important! Never mount or remove the addON card with power on!

IoT card addressing

The card communicates via I2C bus. The device address must be determined before starting work. The ADR dipswitch is used for this purpose (see figure 1, element 2).

ON ■ ■ 1 2	0x68
ON ■ ■ 1 2	0x6C
ON ■ ■ 1 2	0x6A
ON ■ ■ 1 2	0x6E

Analog inputs configuring

Ai1, Ai2, Ai3 and Ai4 switches are used to configure analog inputs (see figure 1, element 3).

Ai1/Ai2/Ai3/Ai4	↑ (up)*	-10 to +10 V
Ai1/Ai2/Ai3/Ai4	↓ (down)*	-20 to +20 mA

* assuming that the top of the card is where the edge connector is

- ⚠ Important!** Analog inputs must always be configured before connecting the measurement wires. Change of configuration during operation may cause damage to the channel.
- ⚠ Important!** Take special care with the configuration. Setting the current measurement and connecting to a voltage circuit instead of a current circuit can damage the channel.
- ⚠ Important!** Do not remove the card from the device when the inputs are connected. First disconnect the signal sources, then remove the card.
- ⚠ Important!** It is good practice to run the device and do tests at low voltage/current (not full-scale). This will eliminate errors and avoid dangerous short circuits.

Analog inputs wiring: single-ended measurements

The following figure shows a description of the connector terminals and an example of how to connect devices properly.

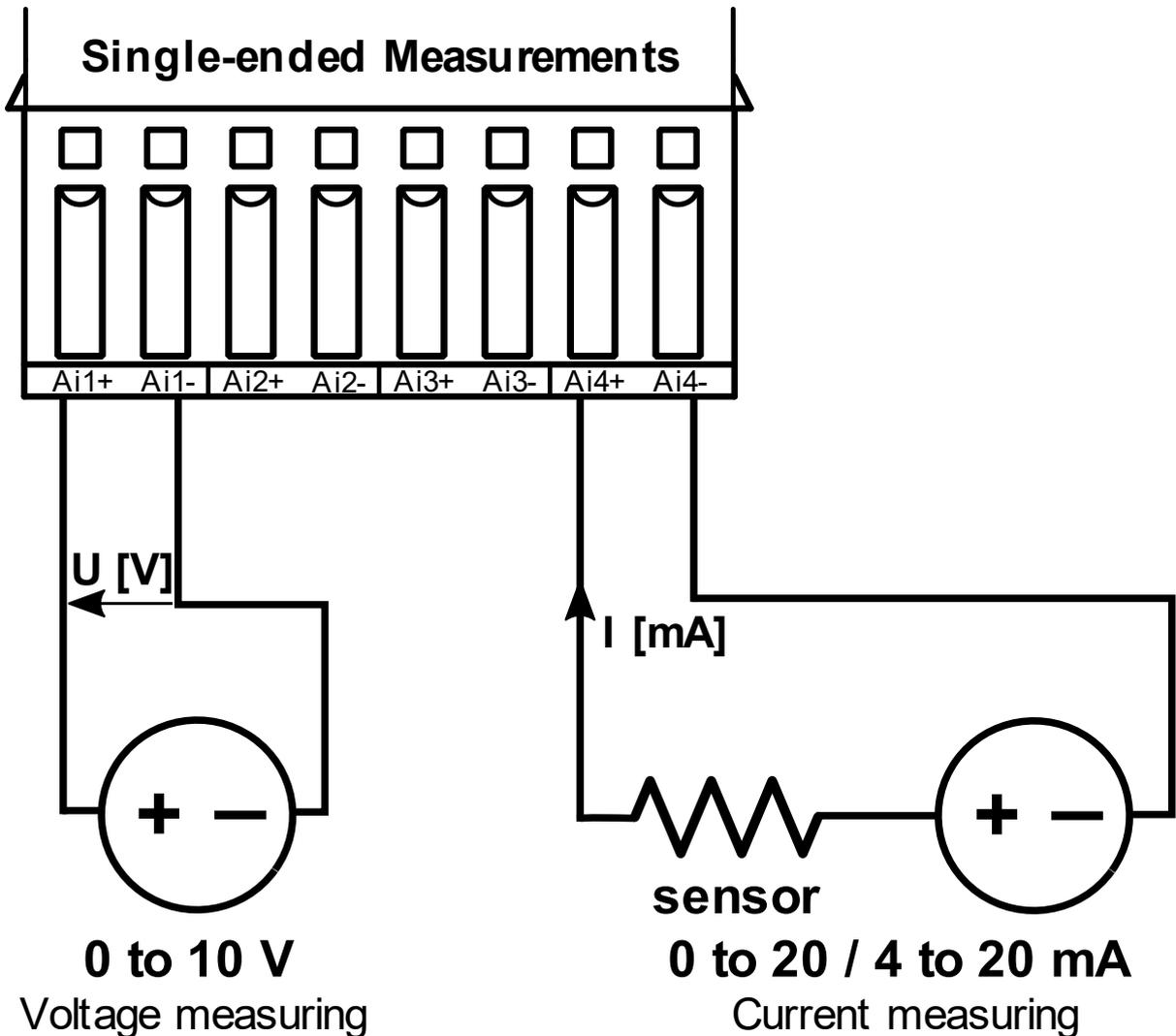

fig. 2

Ai1, Ai2, Ai3, Ai4	analog inputs
C	common

Figure 3 shows how to connect a single-ended signal source. In this case, the Ain- input must be at the ground potential (common).

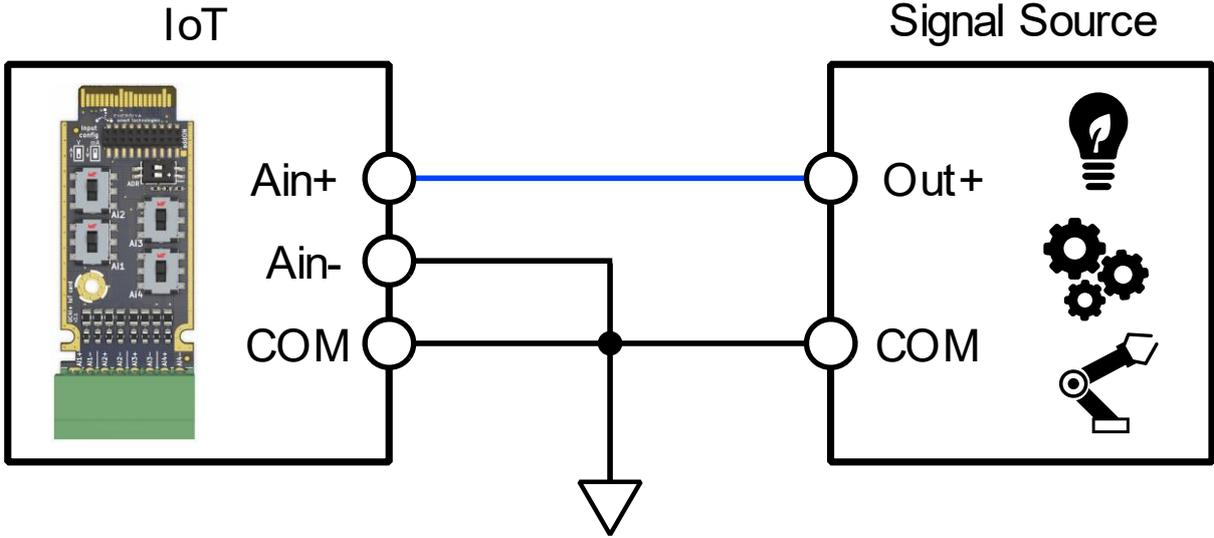

fig. 3

Important! Single-ended measurements are for positive voltages only ($Ain+ > 0$).

The following figure shows an example of a incorrect connection:

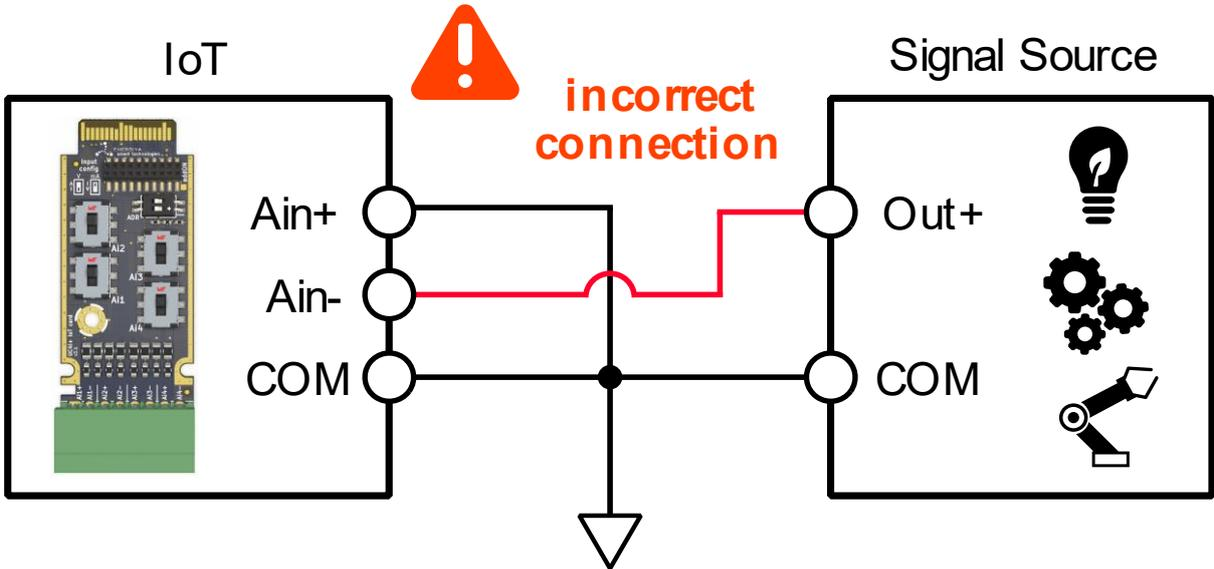

fig. 4

Important! When ground is common, do not apply a voltage of higher potential than $Ain+$ to the input $Ain-$.

Analog inputs wiring: differential measurements

The following figure shows a description of the connector terminals and an example of how to connect devices properly. The general method of connection is the same as for single-ended.

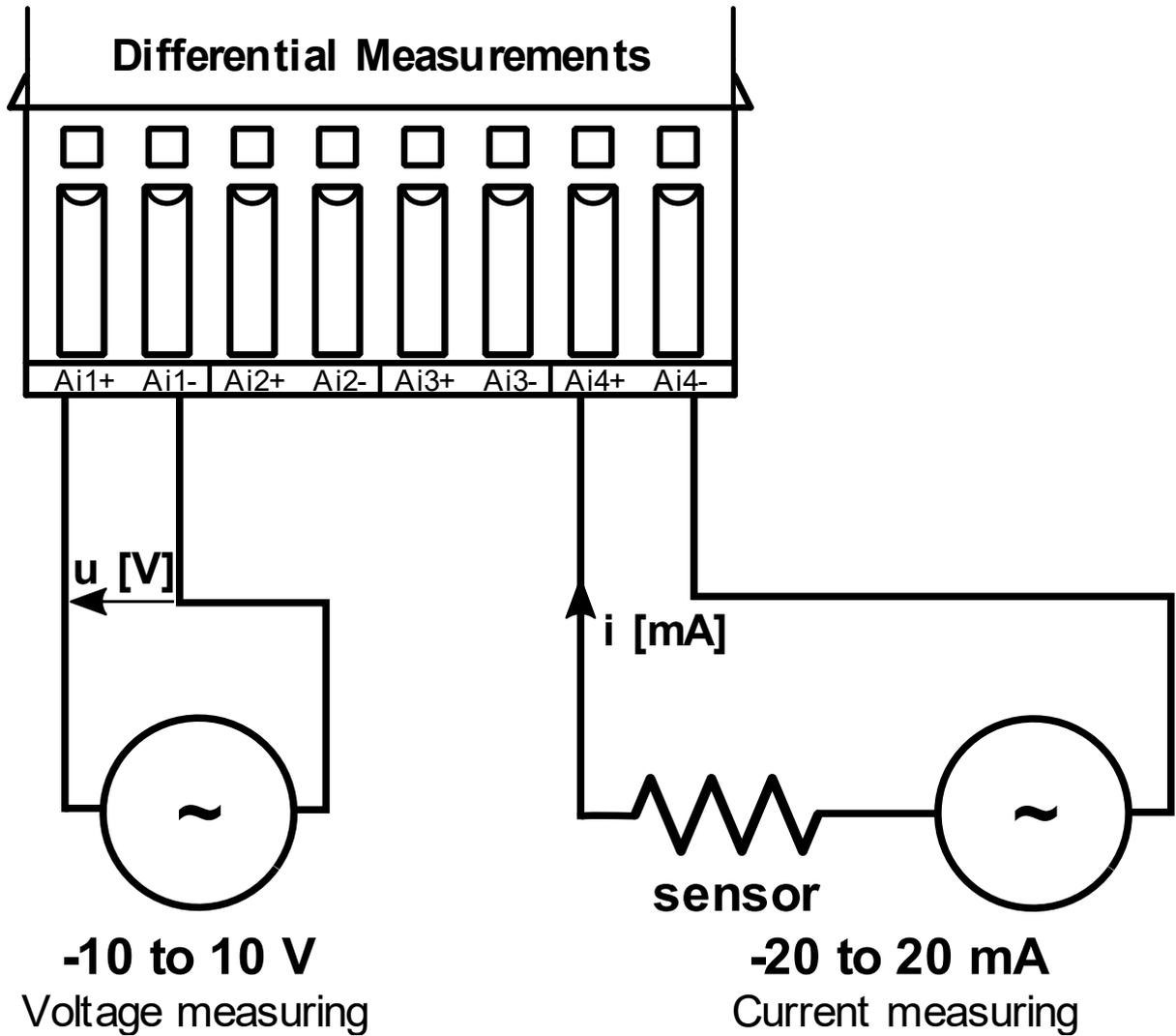

fig. 5

Ai1, Ai2, Ai3, Ai4	analog inputs
C	common

Figure 6 shows the correct way to connect the differential inputs. The ground potential of both devices is not common.

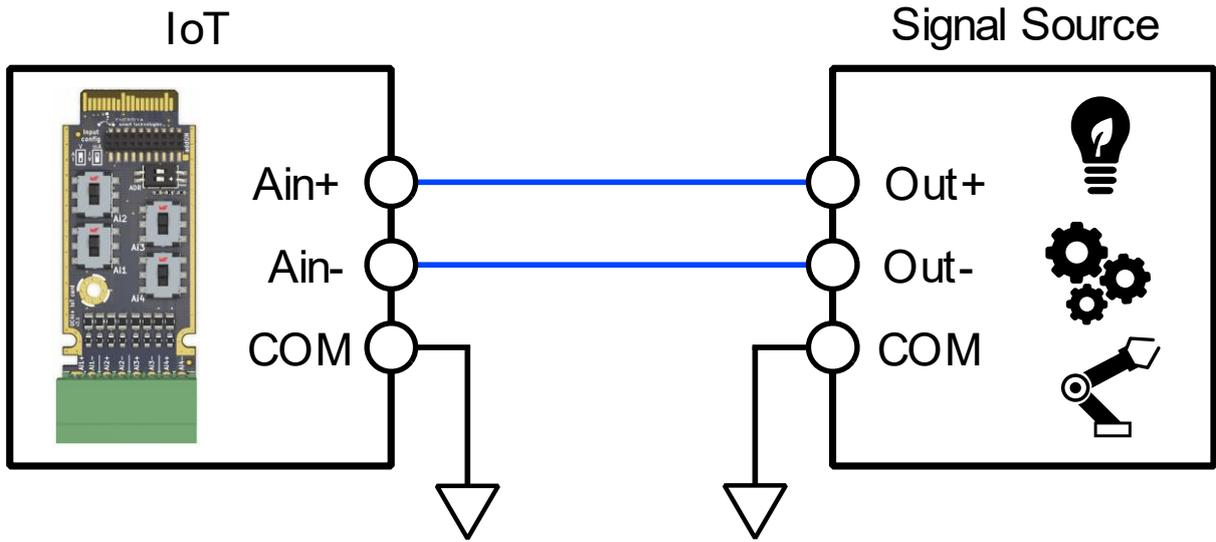

fig. 6

The following configuration with common ground in Figure 7 is only allowed if the measurement signal source has a differential output.

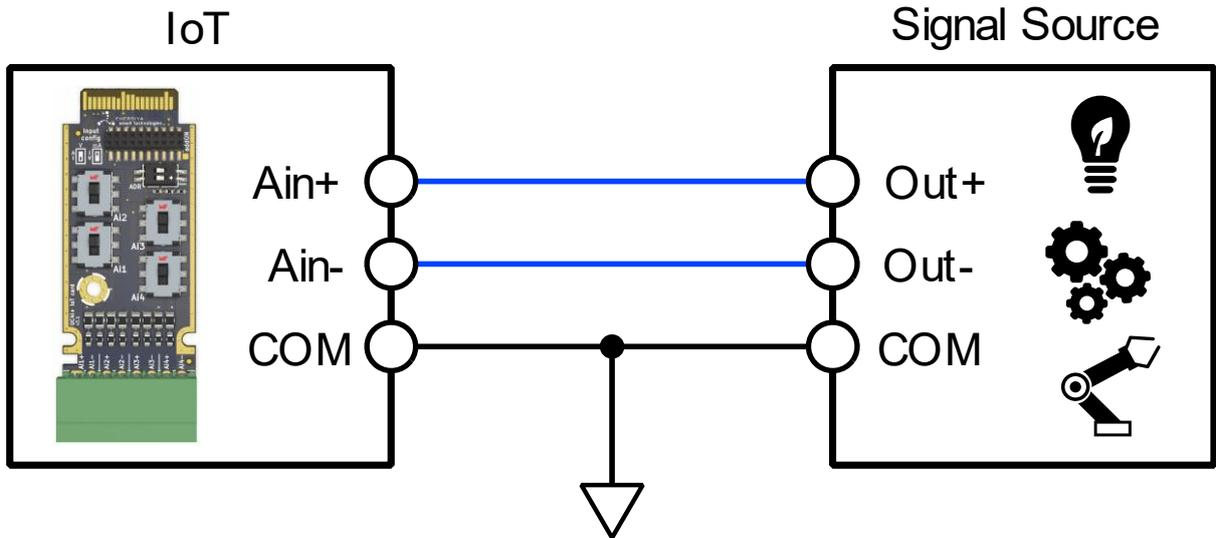

fig. 7

The next two figures (Figure 8 and Figure 9) show the incorrect connection of the measured device.

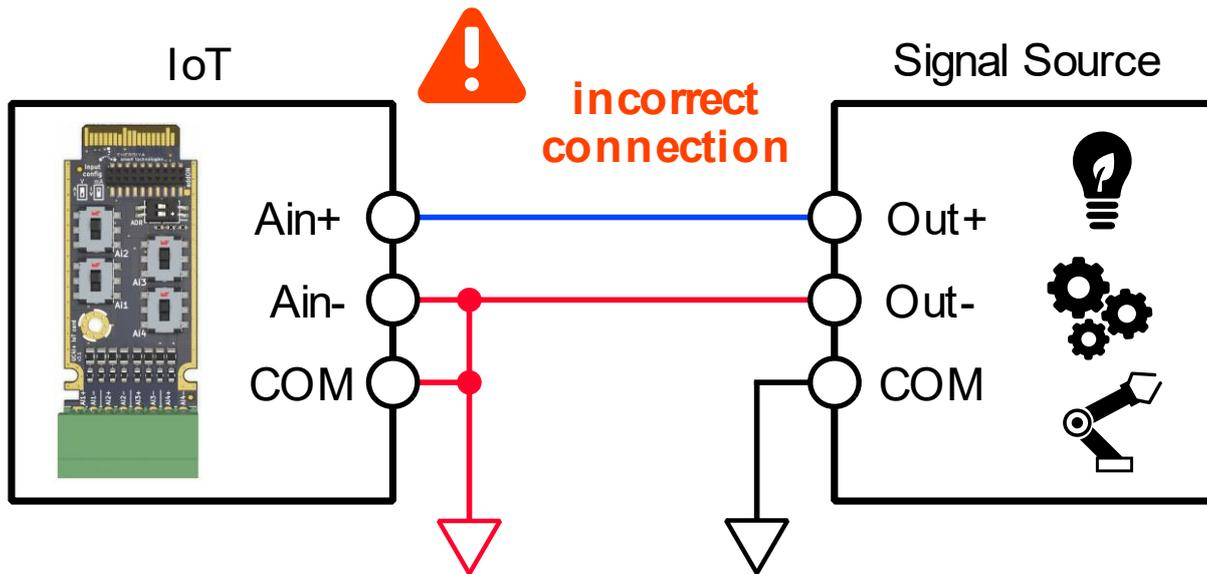

fig. 8

The exception may be the situation in Figure 8, when we assume that the voltage $Ain+$ is only positive, the connection method becomes valid.

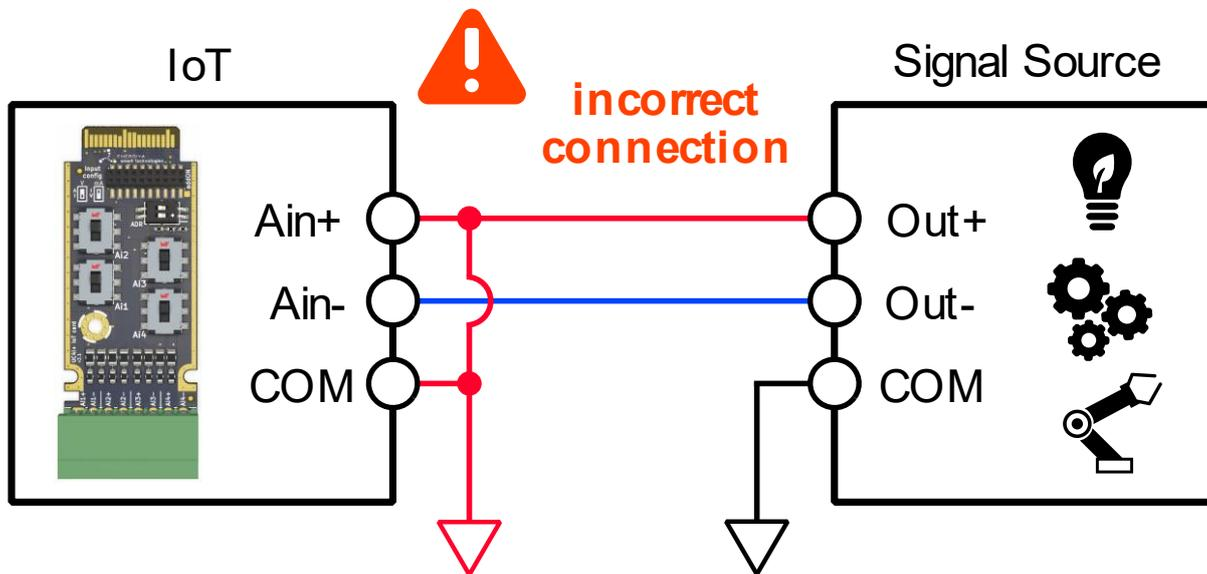

fig. 9

 **Important!** Similar way of incorrectly connecting devices will be for the diagram in Figure 7.

Aliasing

Aliasing occurs when the input signal contains time varying signal components with frequency greater than half the sample rate (SPS – Sample Per Second).

Sample Per Second	ADC resolution	Max. signal frequency
240 SPS	12 bit resolution	120 Hz
60 SPS	14 bit resolution	30 Hz
15 SPS	16 bit resolution	7.5 Hz
3.75 SPS	18 bit resolution	1.8 Hz

In the aliasing conditions, the device can output unexpected output codes. The device has an internal first order sinc filter. If the filter response is not enough, can be accomplished with a simple RC low-pass filter at the input pins. The low-pass filter cuts off the high frequency noise components and provides a band-limited input signal to the input pins.

Specifications

Dimensions (W x H x D)	22.3 x 70.1 x 17.2 mm
Operating temp	-40 to +85°C
Weight	12 g
Current consumption	8 mA
Configurable analog inputs (-20 to 20 mA / -10 to 10 VDC)	4
Programmable data rate options and resolution	3.75 SPS (18 bit resolution) 15 SPS (16 bit resolution) 60 SPS (14 bit resolution) 240 SPS (12 bit resolution)
Programmable gain	x 1 (default) x 2 x 4 x 8
I2C address configuration	4 addresses
Interface connector type	pluggable terminal block
Wire range	0.2 to 1.3 mm ² (24 to 16 AWG)
ESD protection	yes
addON socket	yes
Latching cover for FX30	yes

Troubleshooting

Incorrect or zero measurement results	At first check Ain switch configuration and then check the polarities of connected wires
Too high or too low measurement results	Check programmable gain amplifier
After installation the device does not work	Restart program or host, check I2C address switch or scan I2C bus

Send us your feedback and suggestion to help us improve our products! 😊 info@energiya.pl



Please consider the environment before printing this manual.