

# UC4i+

## Universal Converter + IoT card (v2.3 extended & programmable measuring range)

---

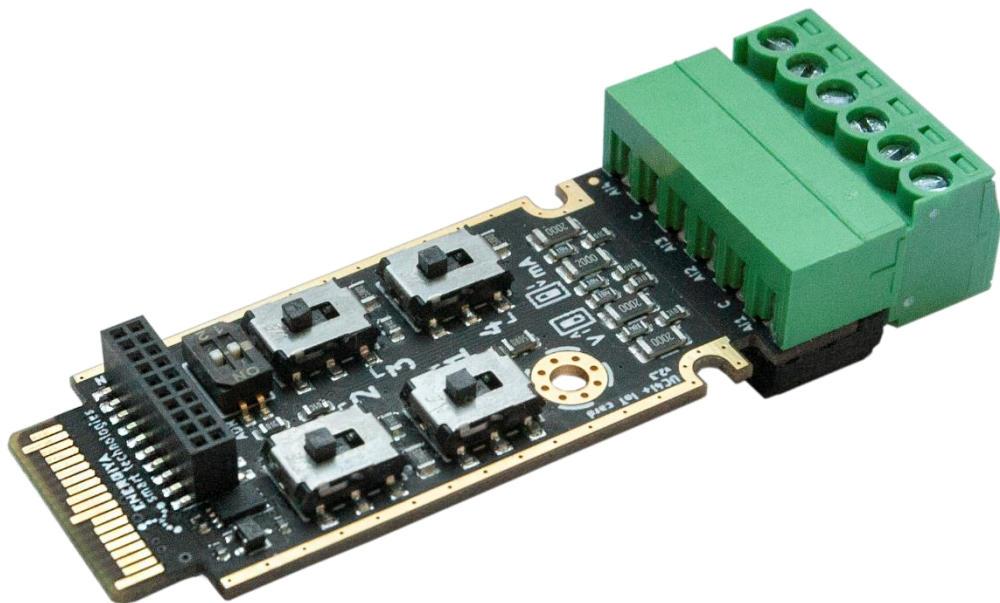

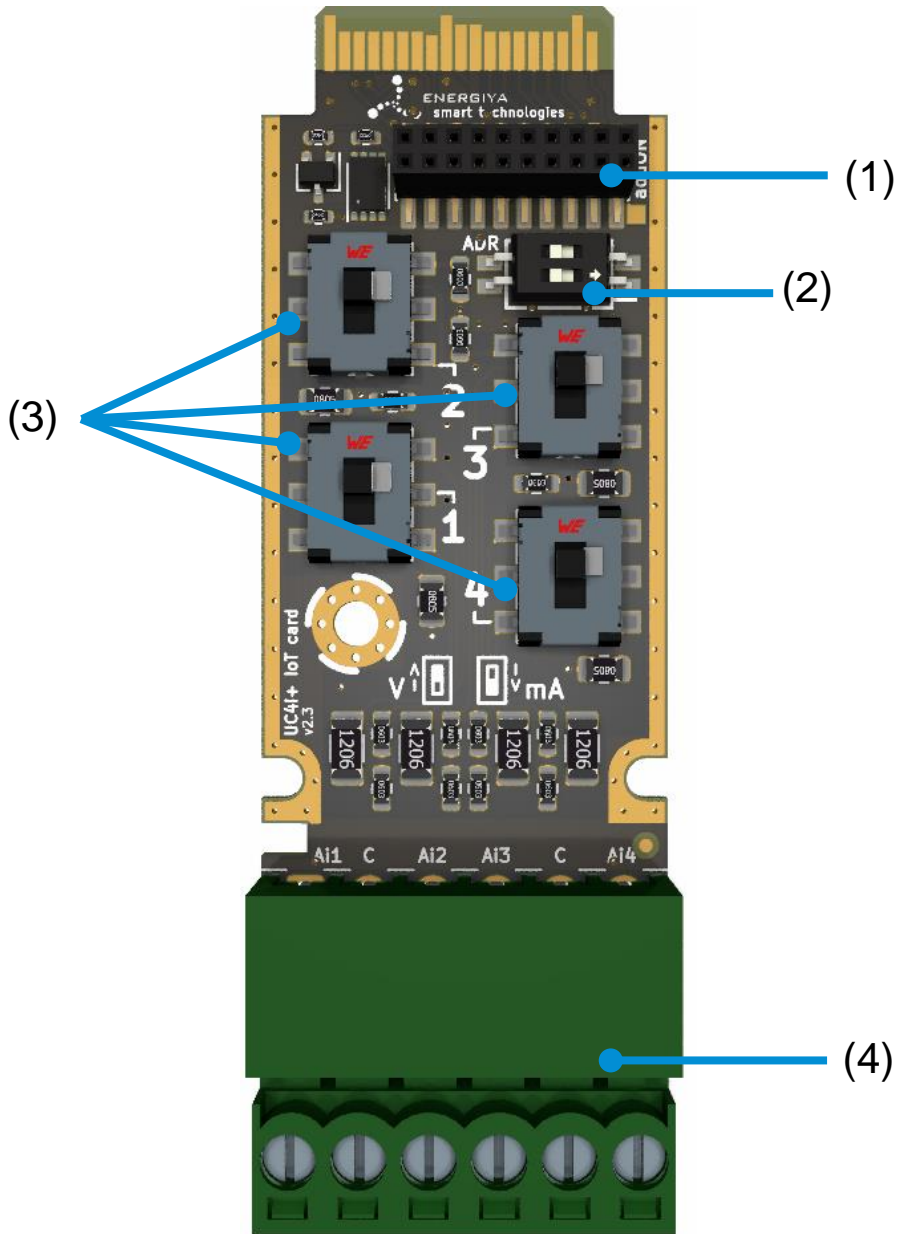

fig. 1

---

(1) addON socket

---

(2) I2C address switch

---

(3) inputs configuration switches

---

(4) analog inputs connector

---

## Description

Universal Converter is 4 configurable analog inputs card. The IoT card allows for current (0 to 40 mA) and voltage (0 to 40 VDC) measurement.

Thanks to a special connector, the device has the possibility to extend its functionality with addON expansion cards.

The IoT card is compatible with mangOH Green, Red, Yellow and FX30 / FX30S.

## Mounting the card in the host

It is recommended to install the IoT card when the power is off to avoid accidental short circuits. If the card is installed with the power on, it is necessary to reboot the program.

Depending on the device used, the card is mounted using standoffs/spacers (mangOH) or rails (FX30). The IoT card also has dedicated cover for locking inside FX30.

 **Important!** Lock the card in the host before use (in mangOH lock in the spacers, in FX30(S) use dedicated cover).

 **Important!** Never mount or remove the addON card with power on!

## IoT card addressing

The card communicates via I2C bus. The device address must be determined before starting work. The ADR dipswitch is used for this purpose (see figure 1, element 2).

ON □ □ 1 2	0x68
ON □ 1 2	0x6A
ON □ □ 1 2	0x6C
ON □ □ 1 2	0x6E

### Analog inputs configuring

Ai1, Ai2, Ai3 and Ai4 switches are used to configure analog inputs (see figure 1, element 3).

Ai1/Ai2/Ai3/Ai4	↑ (up)*	Voltage measuring
Ai1/Ai2/Ai3/Ai4	↓ (down)*	Current measuring

\* assuming that the top of the card is where the edge connector is

- ! Important!** Analog inputs must always be configured before connecting the measurement wires. Change of configuration during operation may cause damage to the channel.
- ! Important!** Take special care with the configuration. Setting the current measurement and connecting to a voltage circuit instead of a current circuit can damage the channel.
- ! Important!** Do not remove the card from the device when the inputs are connected. First disconnect the signal sources, then remove the card.

### Analog inputs wiring

The following figure shows a description of the connector terminals and an example of how to connect devices properly.

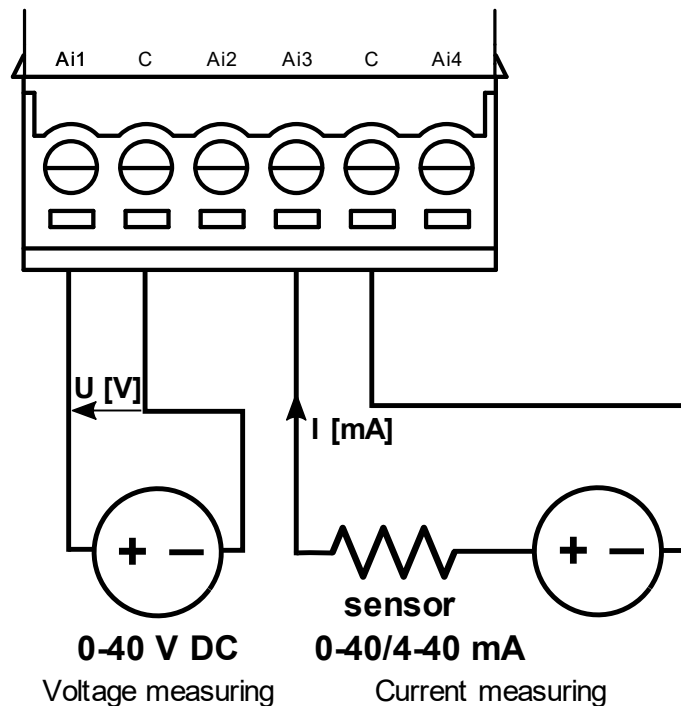

fig. 2

Ai1, Ai2, Ai3, Ai4	analog inputs
C	common

## Specifications

Dimensions (W x H x D)	22.3 x 66.4 x 12.9 mm
Operating temp	-40 to +85°C
Weight	10 g
Current consumption	8 mA
Configurable analog inputs (0-20 mA / 4-20 mA / 0-10 VDC)	4
Programmable data rate options and resolution	3.75 SPS (18 bit resolution) 15 SPS (16 bit resolution) 60 SPS (14 bit resolution) 240 SPS (12 bit resolution)
Programmable full scale measuring range (programmable gain)	x 1 (0-40 V / 0-40 mA) x 2 (0-20 V / 0-20 mA) x 4 (0-10 V / 0-10 mA) x 8 (0-5 V / 0-5 mA)
I2C address configuration	4 addresses
Interface connector type	pluggable terminal block
Wire range	0.12 to 1.5 mm <sup>2</sup> (26 to 16 AWG)
ESD protection	yes
addON socket	yes
Latching cover for FX30	yes

## Troubleshooting

---

Incorrect or zero measurement results	<b>At first</b> check Ain switch configuration and <b>then</b> check the polarities of connected wires
Too high or too low measurement results	Check programmable gain amplifier
After installation the device does not work	Restart program or host, check I2C address switch or scan I2C bus

---

---

Send us your feedback and suggestion to help us improve our products! 😊 [info@energiya.pl](mailto:info@energiya.pl)



Please consider the environment before printing this manual.