

# addON 4i

Digital inputs extension card

---

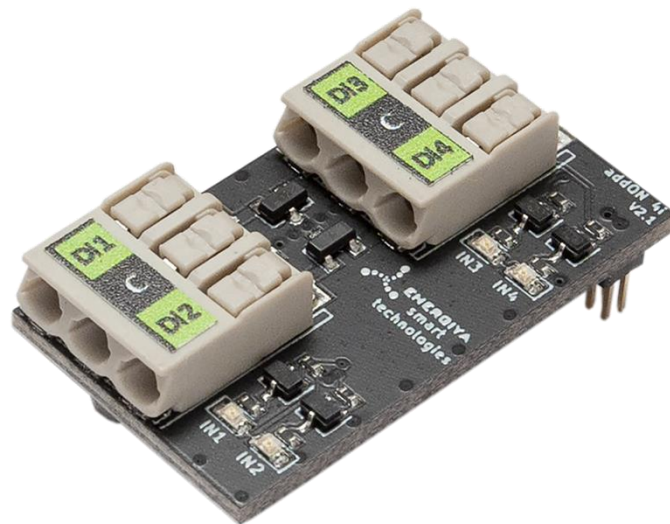

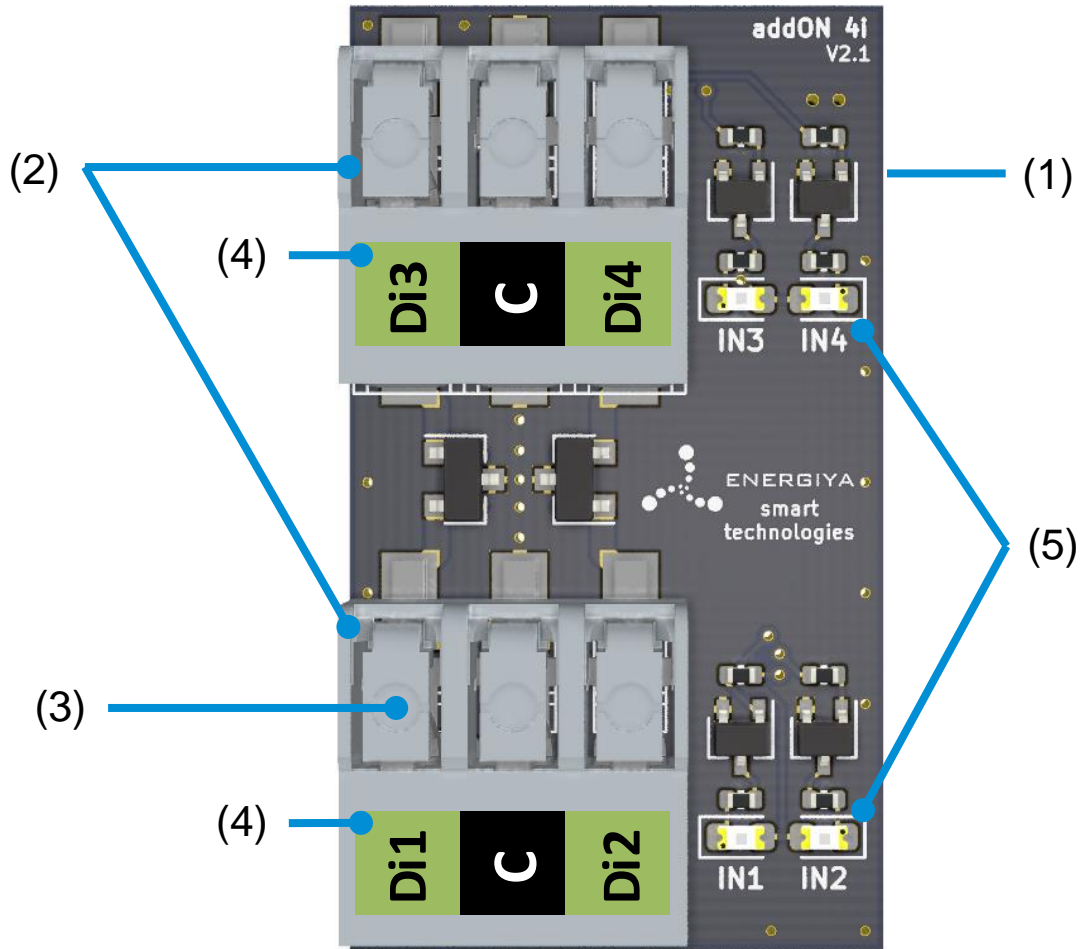

fig. 1

---

(1) addON connector (on bottom side)

---

(2) screwless connectors

---

(3) wire release

---

(4) connector description label

---

(5) input status LEDs

---

### Description

The addON expansion cards allow you to extend the functionality of IoT cards with additional inputs, outputs and interfaces.

Using the addON 4i card we will expand any IoT card by 4 digital inputs.

The addON card is compatible with all of Energiya IoT cards.

### Mounting the addON card

The addON card is mounted on top of the IoT card in a dedicated connector.

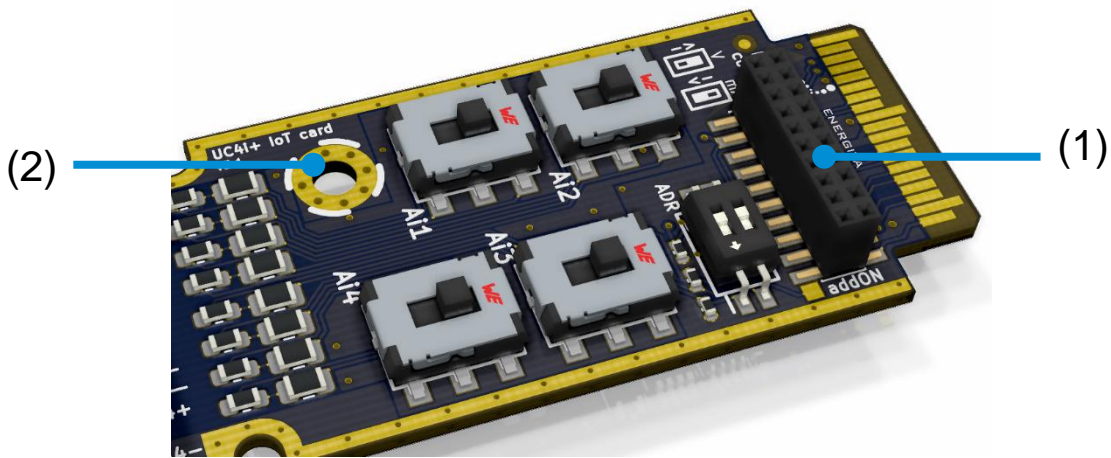

fig. 2

First place the addON card into the slot on the top of the IoT card (1). Then use the polyamide screw (supplied with the addON) to screw the expansion card to the IoT board (2).

There are two types of addON slots. Please find below the picture of correct assembly:

- 18 pin addON slot (fig. 3):

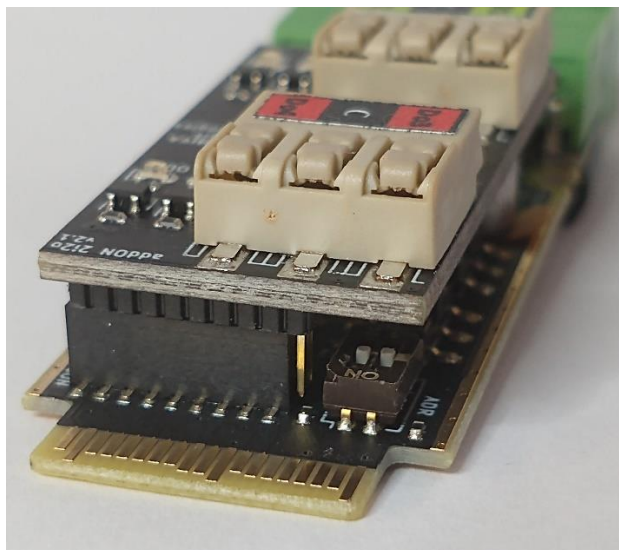

fig. 3

- 20 pin addON slot (fig. 4):

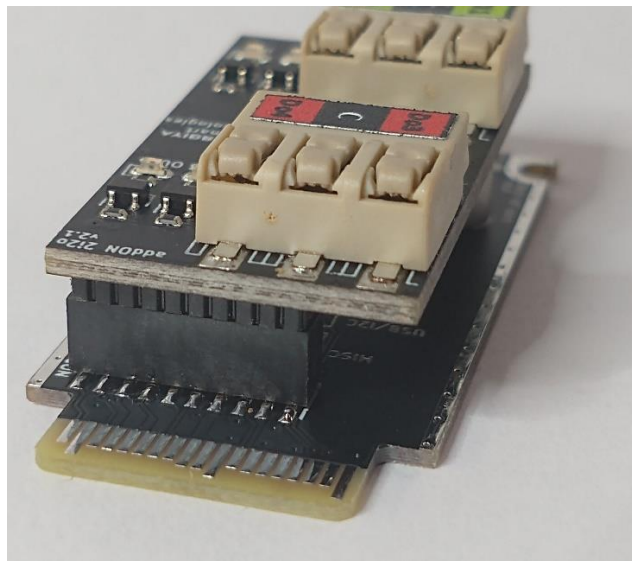

fig. 4

**!** **Important!** Never mount or remove the addON card with power on! This way you can easily cause a short circuit and damage the card.

**!** **Important!** Always remember to secure the card with a polyamide screw! Vibration can make slide out the card out of the connector and cause short circuit.

### Status LEDs

LEDs are used to indicate the current state of the addON inputs.

### Digital inputs wiring

Wire insertion and removal is very simple. To insert the cable, you just have to push it into the connector. To pull the cable out, press the release lever (see figure 1, element 2, 3 and 4).

---

Di1, Di2, Di3, Di4	digital inputs
C	common

---

**!** **Important!** To avoid short circuits, it is recommended to connect or disconnect the cables to the addON when the power is off.

The inputs of the addON card can be controlled by mechanical or electrical trigger:

- 1) Short-circuiting the input to common by means of a switch or relay
- 2) Short-circuiting the input to ground using the open collector (open drain) output. There is no need to pull up the open collector (drain) output on the side of the control device. The common points of the devices must be connected.

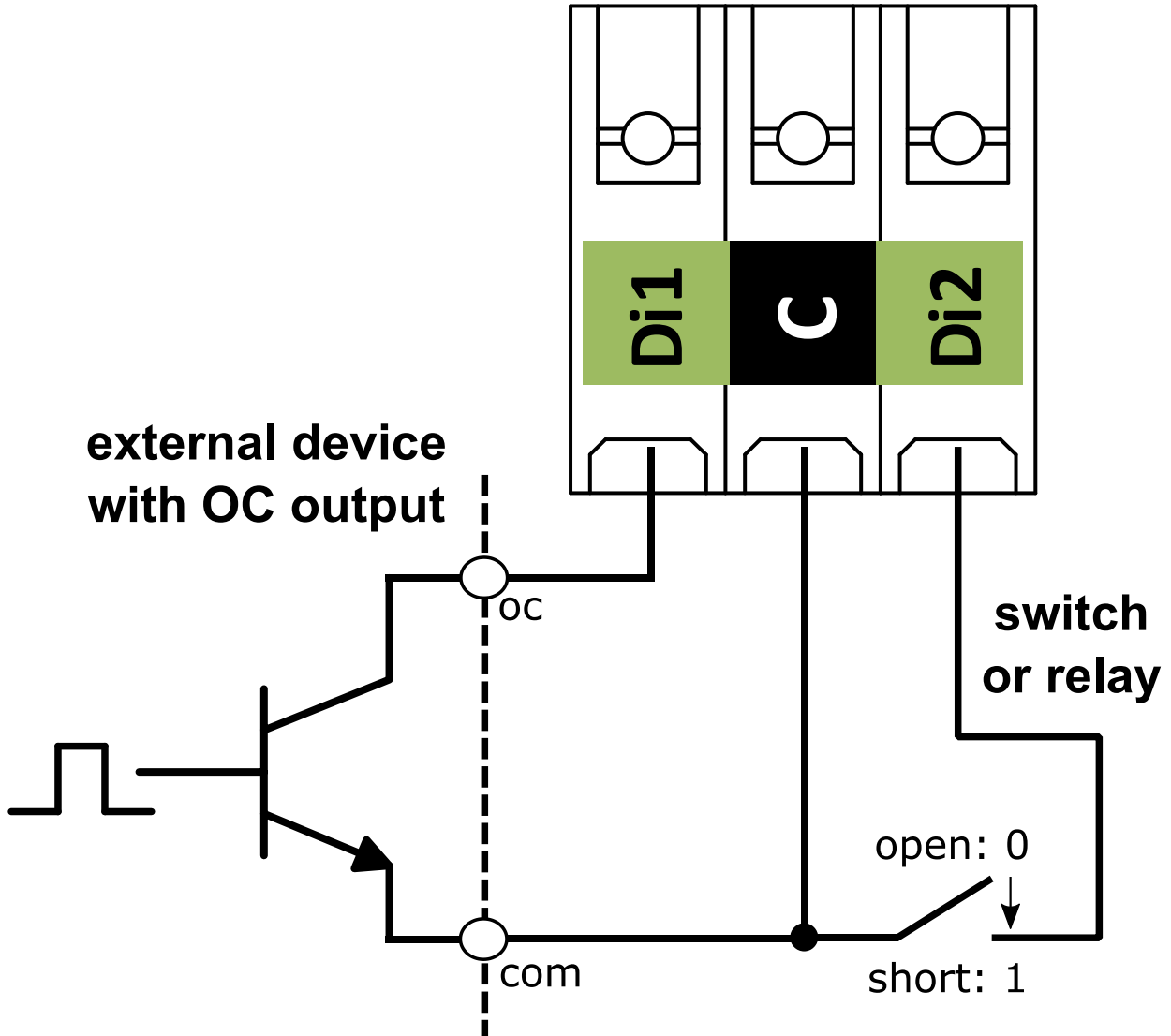

fig. 5

## GPIO host - card connections

The table below shows logical connections between addON card, IoT card and the host.

addON type	IoT card	FX30	manhgOH	manhgOH	manhgOH		
		FX30S	Yellow	Red	Green		
4i	GPIOx	IoT0	IoT0	IoT0	IoT0	IoT1	IoT2
in 1	GPIO 1	GPIO 42	GPIO 42	GPIO 42	GPIO 42	GPIO 25	GPIO 22
in 2	GPIO 2	GPIO 33	GPIO 13	GPIO 13	GPIO 33	GPIO 32	GPIO 23
in 3	GPIO 3	GPIO 13	GPIO 7	GPIO 7	GPIO 32	GPIO 7	GPIO 24
in 4	GPIO 4	GPIO 8	GPIO 8	GPIO 8	GPIO 8	GPIO 21	EXT_GPS

## Specifications

Dimensions (W x H x D)	19.3 x 33.6 x 11.5 mm
Operating temp	-40 to +85°C
Weight	5 g
Current consumption	2 mA
Digital inputs	4
Digital input type	NPN (active low)
Connector type	screwless connector
Wire range	0.2 to 1.0 mm <sup>2</sup> (24 to 17 AWG)
ESD protection	yes
Latching cover for FX30	yes

## Troubleshooting

Digital input does not work

check the mechanical element that triggers is operational, if the control signal is an open collector (drain) make sure that the common signals from addON to external device are connected, watch the LEDs

Send us your feedback and suggestion to help us improve our products! 😊 [info@energija.pl](mailto:info@energija.pl)



Please consider the environment before printing this manual.