

addON 8i

Digital inputs extension card

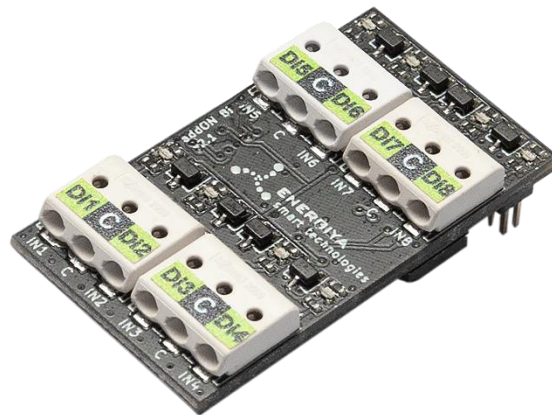

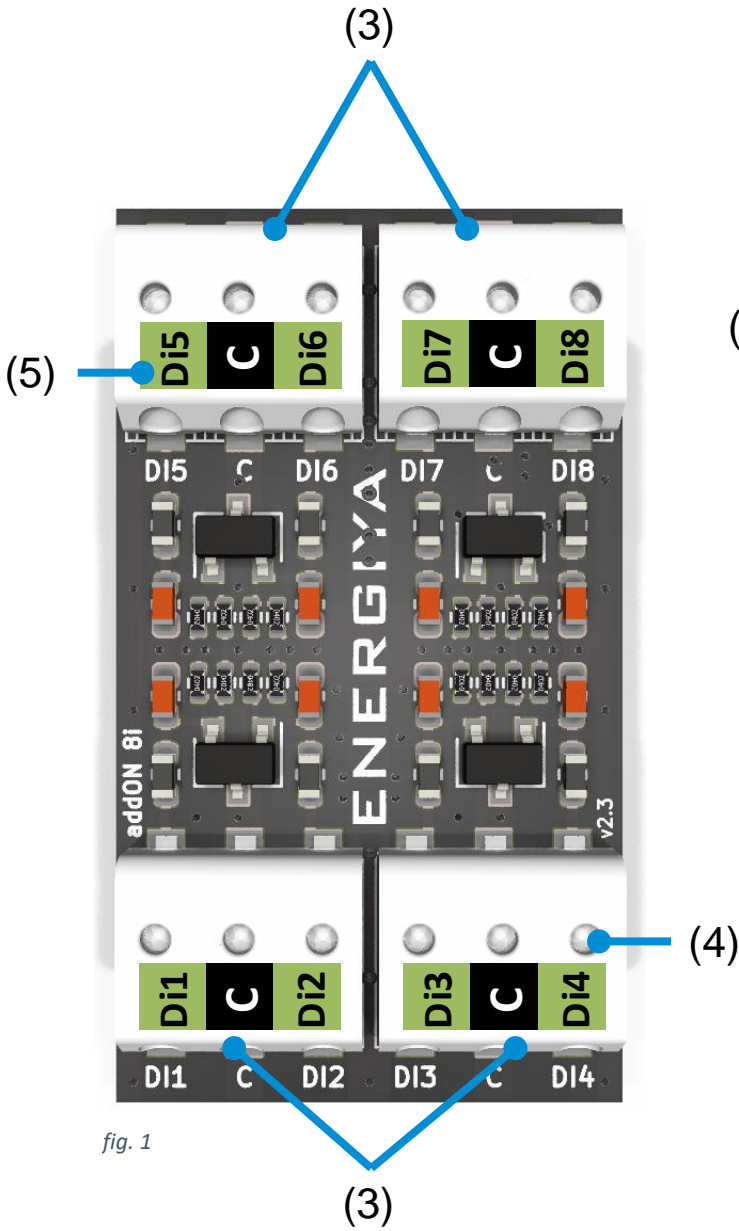

fig. 1

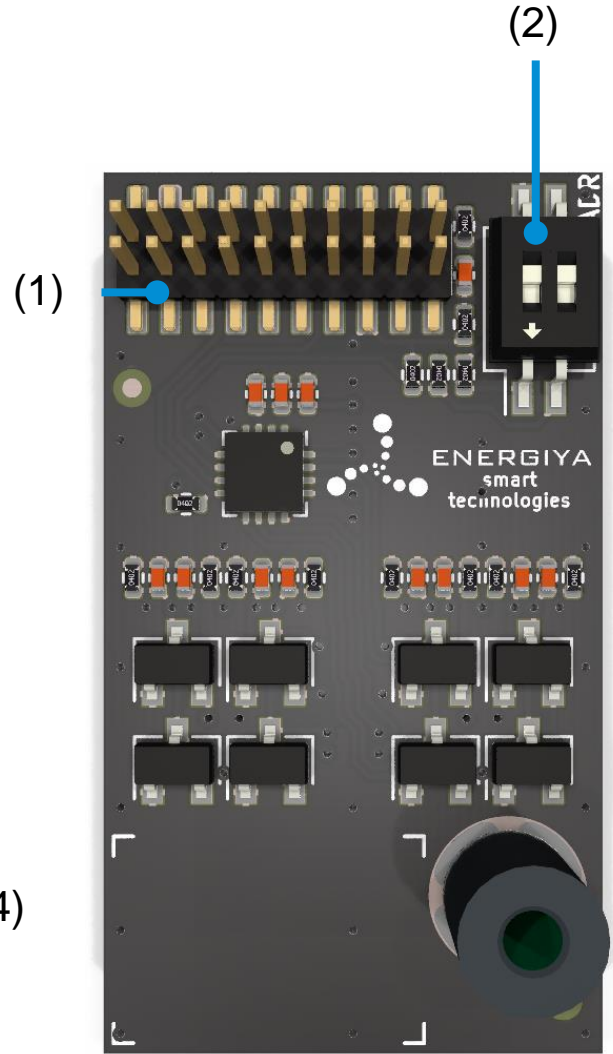

fig. 2

-
- (1) addON connector (on bottom side)
 - (2) I2C address switch (on bottom side)
 - (3) screwless connectors
 - (4) wire release hole
 - (5) connector description label
-

Description

The addON expansion cards allow you to extend the functionality of IoT cards with additional inputs, outputs and interfaces.

Using the addON 8i card we will expand any IoT card by 8 digital inputs.

The addON card is compatible with all of Energiya IoT cards.

Mounting the addON card

The addON card is mounted on top of the IoT card in a dedicated connector.

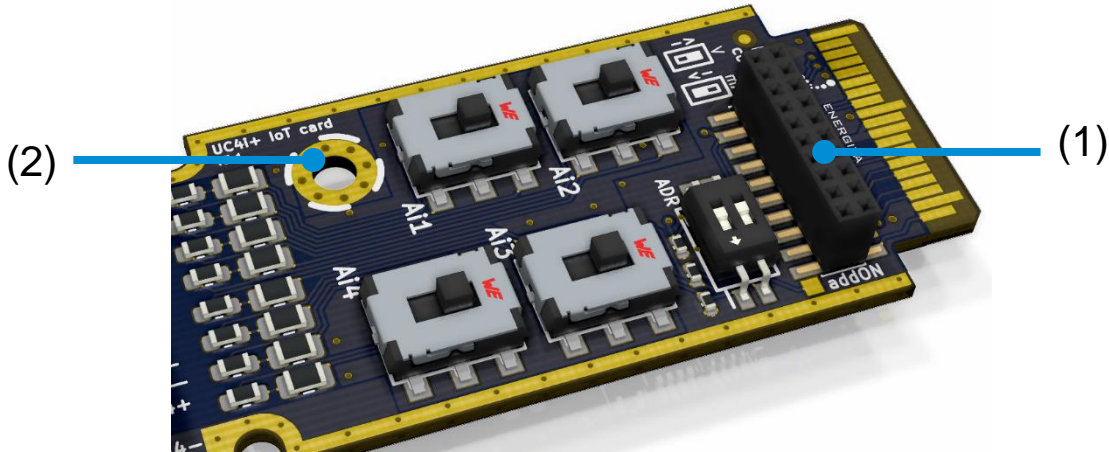

fig. 1

First place the addON card into the slot on the top of the IoT card (1). Then use the polyamide screw (supplied with the addON) to screw the expansion card to the IoT board (2).

There are two types of addON slots. Please find below the picture of correct assembly:

- 18 pin addON slot (fig. 4):

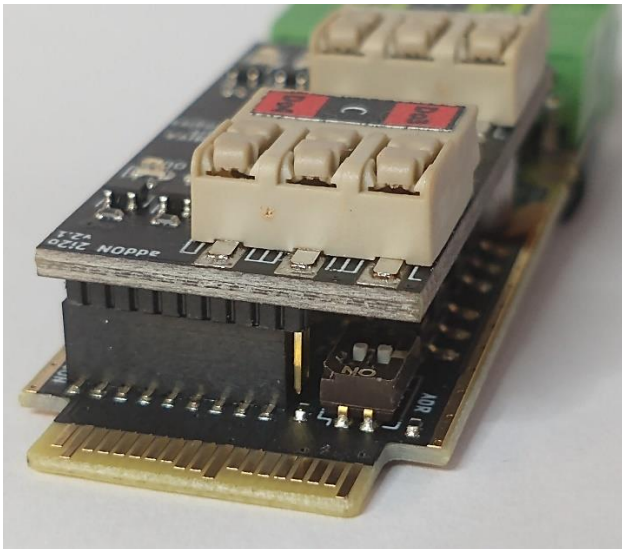

fig. 4

- 20 pin addON slot (fig. 5):

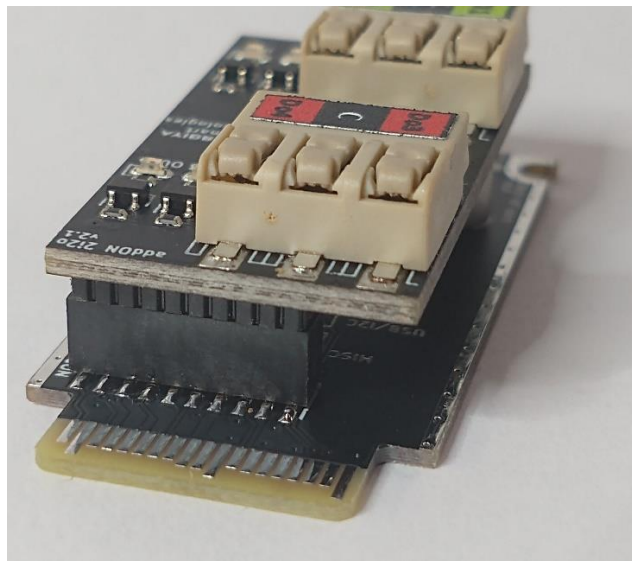

fig. 5

- ! Important!** Never mount or remove the addON card with power on! This way you can easily cause a short circuit and damage the card.
- ! Important!** Always remember to secure the card with a polyamide screw! Vibration can make slide out the card out of the connector and cause short circuit.

addON card addressing

The card communicates via I2C bus. The device address must be determined before starting work. The ADR dipswitch is used for this purpose (see figure 2, element 2).

ON □ □ 1 2	0x23
ON □ □ 1 2	0x22
ON □ □ 1 2	0x21
ON □ □ 1 2	0x20

Digital inputs wiring

Wire insertion and removal is very simple. To insert the cable, you just have to push it into the connector. To pull the cable out, press the release lever (see figure 1 and 2, element 3, 4 and 5).

Di1, Di2, Di3, Di4, Di5, Di6, Di7, Di8	digital inputs
C	common



Important! To avoid short circuits, it is recommended to connect or disconnect the cables to the addON when the power is off.

The inputs of the addON card can be controlled by mechanical or electrical trigger:

- 1) Short-circuiting the input to common by means of a switch or relay
- 2) Short-circuiting the input to ground using the open collector (open drain) output. There is no need to pull up the open collector (drain) output on the side of the control device. The common points of the devices must be connected.

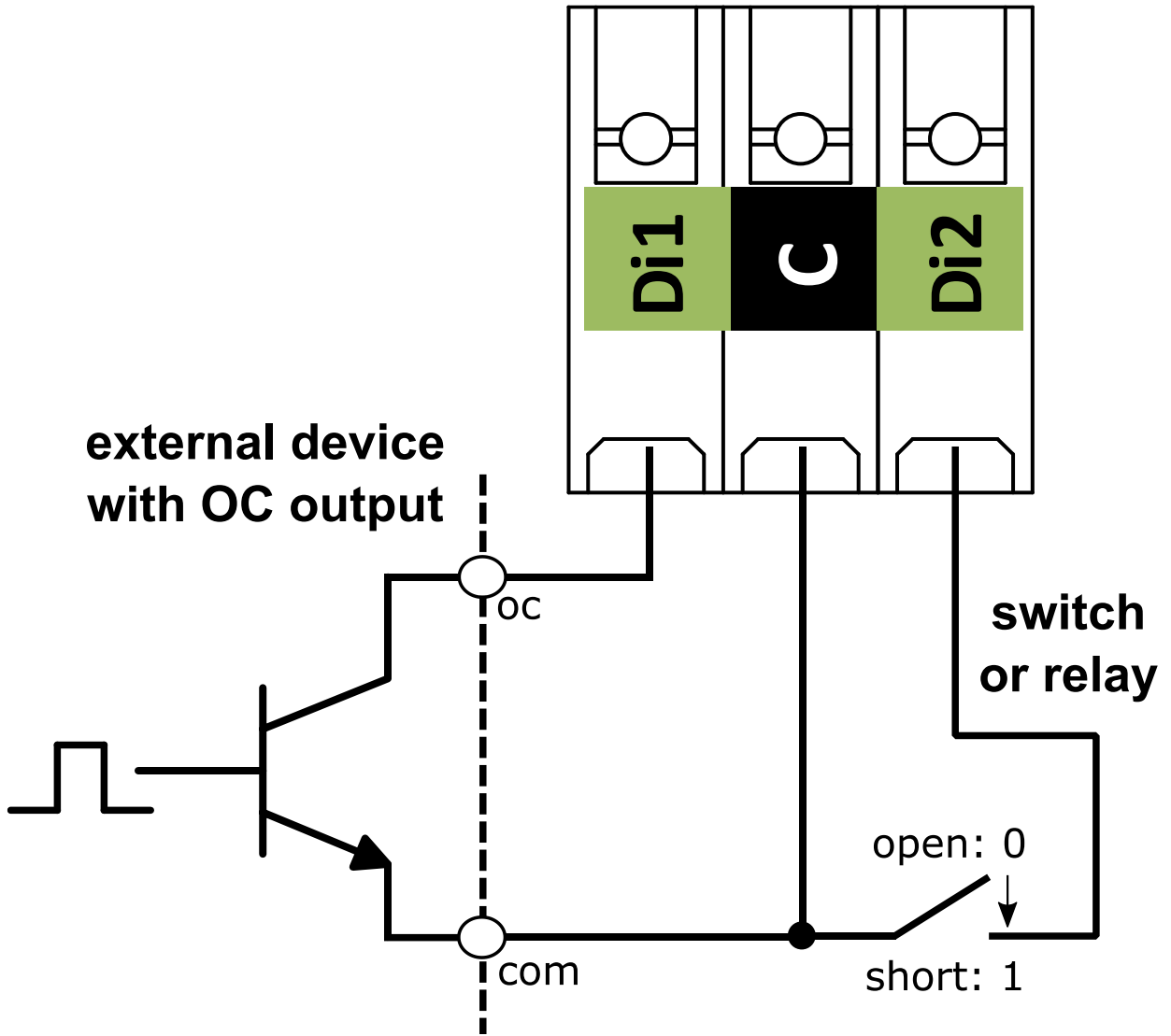

fig. 6

Specifications

Dimensions (W x H x D)	19.3 x 33.6 x 11.5 mm
Operating temp	-40 to +85°C
Weight	5 g
Current consumption	2 mA
Digital inputs	8
Digital input type	NPN (active low)
Connector type	screwless connector
Wire range	0.14 to 0.5 mm ² (26 to 20 AWG)
ESD protection	yes
Latching cover for FX30	yes

Troubleshooting

Digital input does not work	check the mechanical element that triggers is operational, if the control signal is an open collector (drain) make sure that the common signals from addON to external device are connected
After instalation the device does not work	restart program or host, chcek I2C address switch or scan I2C bus

Send us your feedback and suggestion to help us improve our products! 😊 info@energiya.pl



Please consider the environment before printing this manual.